

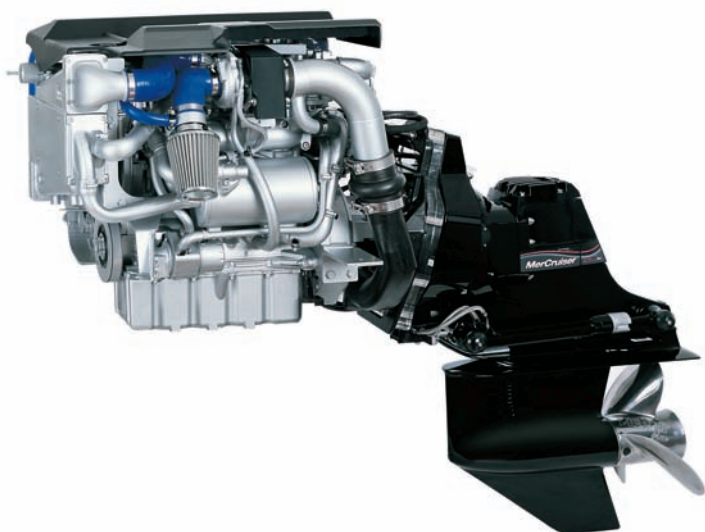

MARINE DIESEL ENGINES



FNM HPEP 190

Configuration	4-stroke cycle, twin camshaft, 16 V
Maximum output at crankshaft	140 kW/190 hp at 4000 rpm
Maximum output at propeller	132.7 kW/185 hp at 4000 rpm
Maximum torque	372 Nm at 2400 rpm
Displacement	1.910 c.c.
Bore x stroke	82 x 90,4 mm
Cylinders	4, in-line
Combustion system	Direct injection Common rail
Aspiration	Supercharged with variable geometry turbo
Starting system	Electric starting 12 V – 2,1 kW
Alternator	14 V – 105 A
Cooling system	Double water cooling system with heat exchanger
Lubrication system	Totally enclosed, forced lubricating system with pump
Max. mounting inclination	14°
Dry weight without gear	240 kg
Environmental	Meets the EU comprehensive emissions regulation 2006
Engine mounting	Rubber type anti-vibration mounting

Performance Curves (Output is according to ISO 8665)

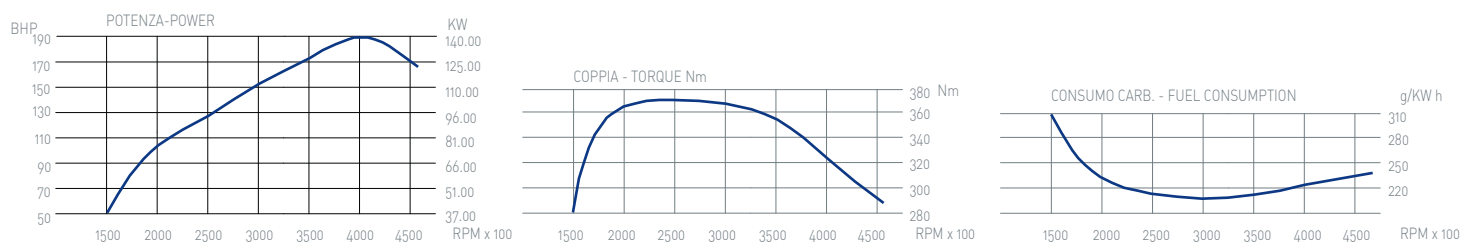

Dimensions (For detailed line-drawings, please refer to our website www.fnm-marine.com or contact your supplier)

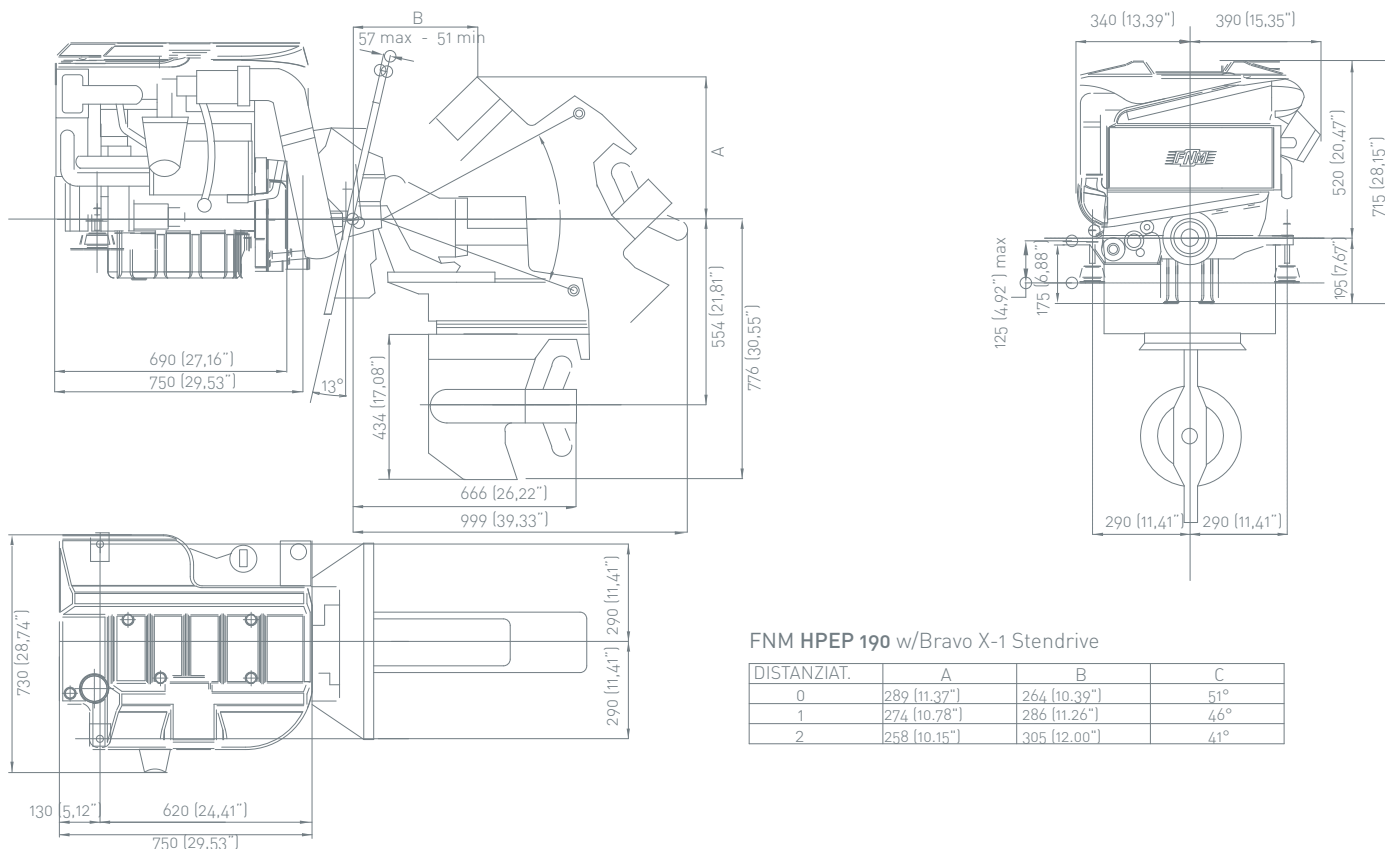

Instrument Panel

- VDO Oil pressure
- VDO Water temperature
- VDO Voltmeter
- VDO Rpm counter
- VDO Trim gauge
- 8 meter cable

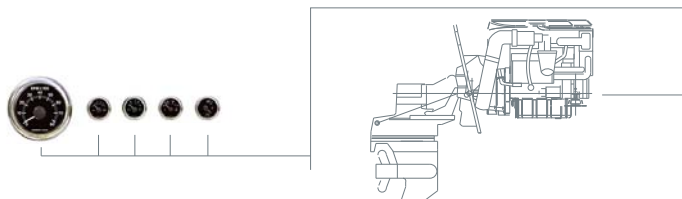

Accessories

Standard Package

- Bravo X-1 stern drive Red. 1,65:1
- Transom
- Set of flexible mounts
- Alternator 14 V - 105 A with built-in regulator
- Starter motor 12 V - 2,1 kW
- Oil and fuel filters
- Water-cooled exhaust manifold
- Bronze seawater pump

- Stainless steel seawater-cooled elbow
- High riser mixing and exhaust mixing elbows
- Original Mercruiser power steering system (complete)
- Racor filters
- Exhaust riser
- Instrument panel with 8 mt. cable and separate VDO gauges
- Engine top cover

Optional

- Dashboard single and double remote control
- CAN single and double remote control
- "Mirage" stainless steel propeller for Bravo X-1
- Multiple Sterndrive Steering Tie Bar Arrangement
- Kit for boat internal heating

- 2 mt. auxiliary extension cable
- Flybridge instrument panel

Text and illustrations are not binding. CMD, owner of the FNM brand, reserves the right to introduce adaptations without prior notification. Compliant with the RCD 2003/44/CE and EPA emission standards.

